

REV	DATE	DRAWN/CHKD	DESCRIPTION						
A	09APR2002	GDM	UPDATE FORMAT						

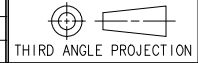

A4
PAPER
SIZE

SOUTHCO PERFORMANCE GUIDELINES
THE PERFORMANCE GUIDELINES SHOWN ON THIS PAGE ARE SUPPLIED AS A GENERAL GUIDE ONLY, AS CONDITIONS VARY WITH EACH APPLICATION AND METHOD OF INSTALLATION. STRENGTH DATA GIVEN IS FOR FAILURE OF THE PRODUCT OR FOR SUFFICIENT DEFORMATION TO MAKE PRODUCT INOPERABLE. NO SAFETY FACTOR HAS BEEN APPLIED IT IS RECOMMENDED THAT THE USER REQUEST A PRODUCT SAMPLE FOR TESTING TO DETERMINE THE SUITABILITY OF THE PRODUCT FOR THE PURPOSE INTENDED AND USER'S PARTICULAR APPLICATION.

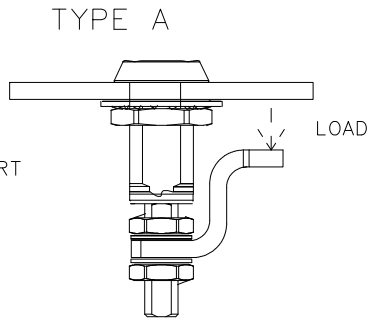

ASSEMBLY PART NUMBER:
E3-1X-X0
E3-11X-X0

	TYPE A	TYPE B
MAXIMUM RECOMMENDED TIGHTENING TORQUE FOR MOUNTING NUT	20 N·m (177 lbf·in)	
MAXIMUM RECOMMENDED TIGHTENING TORQUE FOR PAWL SECURING NUTS/SCREW	20 N·m (177 lbf·in)	10 N·m (89 lbf·in)
AVERAGE COMPRESSION FORCE	150 N (34 lbf)	
AVERAGE ULTIMATE LOAD ON PAWL	2355 N (530 lbf)	748 N (168 lbf)
MAXIMUM RECOMMENDED WORKING LOAD	600 N (135 lbf)	450 N (101 lbf)

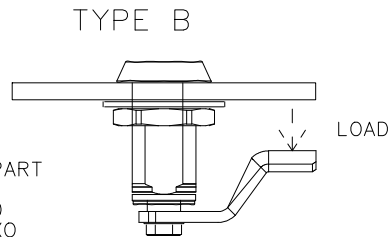

ASSEMBLY PART NUMBER:
E3-10X-XX0
E3-101X-XX0
E3-12X-XX0
E3-121X-XX0

CYCLE LIFE:
-GREATER THAN 10,000 CYCLES AT 150 N (34 lbf) COMPRESSION LOAD WITH APPLIED FRAME RETENTION LOAD AT EACH CYCLE 600 N (135 lbf).
-CYCLE TEMPERATURE RANGE -40°C TO 85°C.

SALT SPRAY EXPOSURE:
-ACHIEVED 500 HOURS PER *ASTM DESIGNATION: B 117-94*.
-SOME SURFACE DISCOLORATION MAY OCCUR WITHOUT LOSS OF PRIMARY FUNCTION.

AVERAGE COMPRESSION FORCE - THE COMPRESSION FORCE APPLIED TO THE FRAME WHEN A STANDARD SOUTHCO KEY IS TURNED BY HAND.

MAXIMUM WORKING LOAD - THE MAXIMUM RECOMMENDED LOAD AT WHICH THE PRODUCT CONTINUES TO FUNCTION PROPERLY.

AVERAGE ULTIMATE LOAD - THE LOAD THAT CAUSES FAILURE OR EXCESSIVE DEFORMATION WHICH RENDERS THE PRODUCT INOPERABLE.