

# southco®

PROPRIETARY ITEM - EXCEPT FOR USES EXPRESSLY GRANTED IN WRITING INFORMATION DISCLOSED HEREON IS CONFIDENTIAL AND ALL RIGHTS PATENT AND OTHERWISE ARE RESERVED BY SOUTHCO, INC.

No. 93 SLAM - ACTION PUSH BUTTON LATCH  
CORROSION - RESISTENT

DATE	DRAWN	CHKD	SCALE	DRAWING NUMBER
04JAN1991	JAD		FULL	J-93-308

REV	DATE	DRAWN/CHKD	DESCRIPTION	ASSEMBLY	MATERIAL	FINISH		
A	19APR1991	ACZ	PRN - 93 - 113	93-308	SEE NOTE A	SEE NOTE A		
B	14MAY1991	CRW	ADDED TOLERANCE TO MOUNTING HOLE	93-308B	SEE NOTE A	SEE NOTE A		
C	02JUN1993	JGK	PRN: 96 - 106 & M3 WAS 3.5mm					
D	15APR1994	RDG	PRN: 93 - 144					
E	21MAR1995	RDG	PRN: 93 - 158					
F	14APR2008	ACH/MJS	PRN: P2008-0391					

**INCHES**  
TOLERANCES UNLESS OTHERWISE NOTED  
TWO PLACE (.XX) ±.01  
THREE PLACE (.XXX) ±.005  
ANGLES ±1°  
THIRD ANGLE PROJECTION  
A PAPER SIZE

NOTES:

- A. MATERIAL AND FINISH  
KEEPER, CAM SPRING & LOCKWASHER: STAINLESS STEEL, PASSIVATED  
MOUNTING NUT & HOUSING: GLASS REINFORCED NYLON, BLACK  
PAWL SPRING: STAINLESS STEEL, NATURAL  
PULL TAB: NYLON, BLACK  
INTERNAL CAM: GLASS REINFORCED NYLON/SILICONE, BLACK  
KNOB & KNOB PLUG: THERMOPLASTIC POLYESTER, BLACK  
PAWL: ACETAL, BLACK

- B. 7.9 N-m (70 in-lbs) MAX TIGHTENING TORQUE

ASSEMBLY PART NUMBER 93-308

ASSEMBLY CONSISTS OF ONE LATCH SUB-ASSEMBLY AND HARDWARE, PACKAGED ONE COMPLETE ASSEMBLY PER BAG.

ASSEMBLY PART NUMBER 93-308-B

SAME AS ABOVE ASS'Y EXCEPT LATCH SUB-ASS'Y AND HARDWARE ARE SHIPPED SEPARATELY.

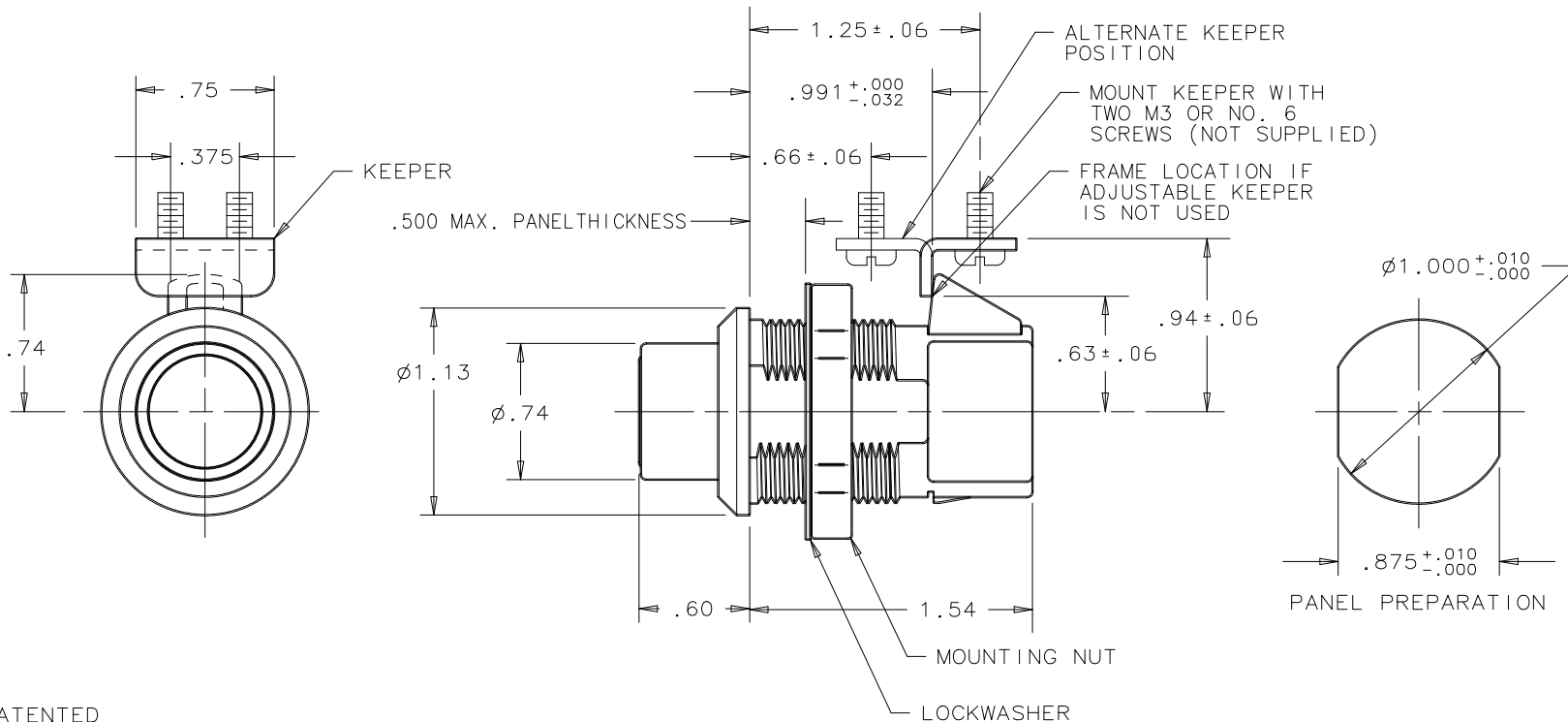

PATENTED