

# southco®

PROPRIETARY ITEM - EXCEPT FOR USES EXPRESSLY GRANTED IN WRITING INFORMATION DISCLOSED HEREON IS CONFIDENTIAL AND ALL RIGHTS PATENT AND OTHERWISE ARE RESERVED BY SOUTHCO, INC.

## SOUTHCO NUMBER E3 KNOB OPERATED VISE ACTION LATCH

DATE: 12-18-86  
DRAWN: GJC  
CHKD:  
SCALE: .75:1

DRAWING NUMBER: J-E3-10-506-50

REV.	DATE	DRAWN	REVISION	ITEM	MATERIAL & FINISH	ITEM	MATERIAL & FINISH	ITEM	MATERIAL & FINISH
C	23NOV87	GJC	PRN: E3-103 DAC NUTS	HOUSING	SEE NOTE A	O-RING	BUNA-N RUBBER	KNOB SPACER	NYLON, BLACK
D	02JUN88	RES	PRN: E3-118; E3-115	CAM	1075 STEEL, TM HARDENED, DACROTIZED	PIN	1008 STEEL, ZINC PLATE CHROMATE DIP, YELLOW		
E	12JAN93	KPL	PRN: S-1-103	KNOB	GLASS FILLED NYLON, BLACK	PAWL	1010 STEEL, SEE NOTE B		
F	02MAY2002	AJH/JSS	PRN: P2002-0125	SHAFT	LOW CARBON STEEL, SEE NOTE B	NUT (2)	STEEL, SEE NOTE B		
G	14MAR2012	CMS/JED	PRN: P2012-0145	SPRING	302 STAINLESS STEEL, NATURAL	LOCKWASHER (2)	SPRING STEEL, SEE NOTE B		
				SLEEVE	1075 STEEL, TM HARDENED, DACROTIZED	WASHER	1010 STEEL, SEE NOTE B		
				RETAINER	POLYCARBONATE, BLACK	NUT	STEEL OR BRASS, SEE NOTE B		

MILLIMETER [INCH] DIMENSIONS  
DIMENSIONS WITHOUT TOLERANCES ARE FOR REFERENCE ONLY.  
THIRD ANGLE PROJECTION  
A4 PAPER SIZE

- NOTES:
- OPERATION:  
195° TURN OF KNOB CAUSES PAWL TO ROTATE 75° AND THEN PULL UP 6.4 [.25]
  - PAWL, NUTS, LOCKWASHERS WASHER AND NUT SHIPPED UNASSEMBLED IN BAG WITH LATCH SUB-ASSY.
  - CAUTION:  
THE AMOUNT OF PAWL COMPRESSION SHOULD NOT CAUSE THE LATCHING TORQUE TO EXCEED 30 IN-LBS.
  - TM - METAL COATINGS INTERNATIONAL, INC.

ASSEMBLY PART NUMBER:  
**E3-10-506-50**

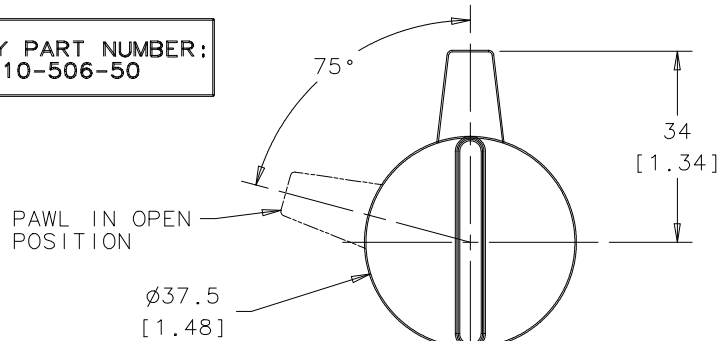

MATERIAL AND FINISH NOTES:

A. DIE CAST ZINC, BLACK POLYESTER POWDER COATING

B. ZINC PLATE, CHROMATE PLUS SEALER

PAT. 4, 556, 244 UK 2, 153, 426  
PAT. 4, 583, 775 UK 2, 158, 866  
UK 2, 172, 334

