

REVISION HISTORY			
REV	DATE	BY	DESCRIPTION
C	12JAN2010	MJS/CLB	PRN: P2010-0030

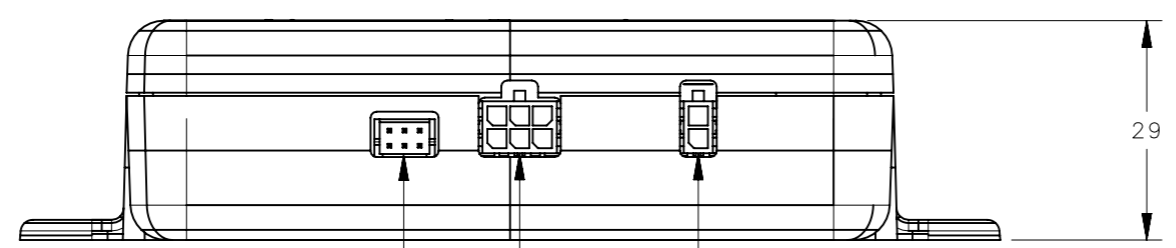
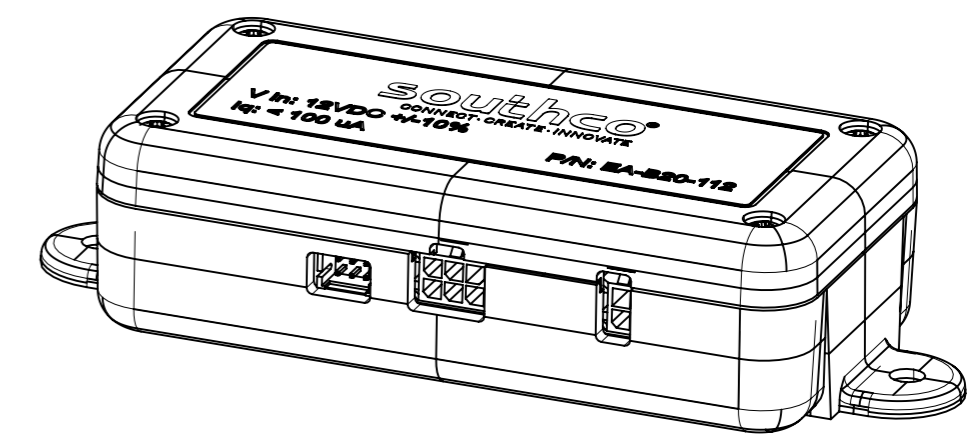
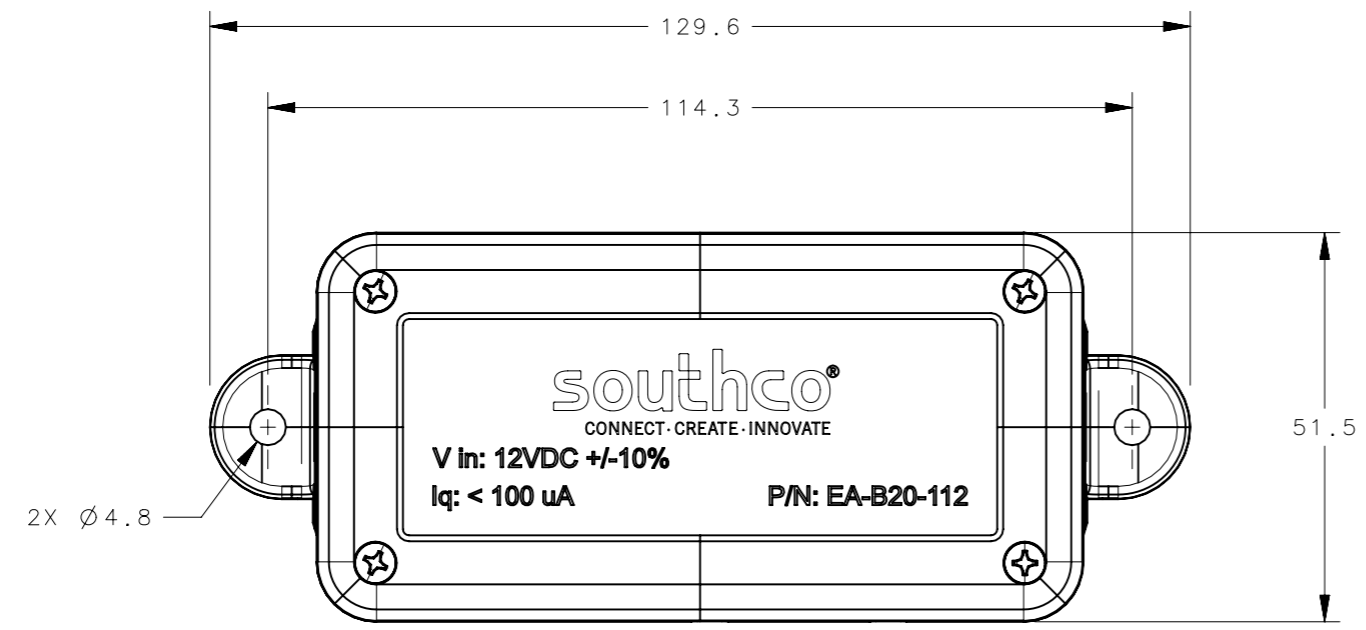
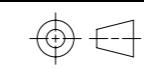

- J3 - POWER CONNECTOR  
MATING CONNECTOR:  
MOLEX 3.00mm PITCH MICRO-FIT 3.0 RECEPTACLE HOUSING, DUAL ROW, 2 CIRCUITS  
PART NUMBER: 43025-0200  
FOR WIRE HARNESS OPTIONS, SEE J-EA-W22-XXX
- J1 - LATCH CONNECTOR  
MATING CONNECTOR:  
MOLEX 3.00mm PITCH MICRO-FIT 3.0 RECEPTACLE HOUSING, DUAL ROW, 6 CIRCUITS  
PART NUMBER: 43025-0600
- J2 - ELECTRONIC KEY READER CONNECTOR  
MATING CONNECTOR:  
HIROSE CONN SOCKET 6 POSITION, 2mm DUAL CRIMP  
PART NUMBER: DF11-6DS-2C  
FOR ELECTRONIC KEY READER OPTIONS, SEE J-EA-B30-11

- NOTES:
- A. MATERIALS ARE RoHS COMPLIANT.
    - 1. HOUSING - ABS
    - 2. PRINTED CIRCUIT BOARD ASSEMBLY - FR4
  - B. ELECTRONIC SPECIFICATIONS:
    - 1. OPERATING VOLTAGE: 12VDC ±10%
    - 2. QUIESCENT CURRENT: 100µ A
    - 3. OPERATING CURRENT: 35mA MAX
    - 4. LATCH COMMAND OUTPUT SIGNAL: 2A MAX
  - C. POWER SOURCE SHOULD BE SIZED BASED ON THE REQUIREMENTS OF THIS CONTROLLER AND THE CONNECTED LATCH(S).
  - D. FOR USE WITH SOUTHCO ELECTRONIC KEY SYSTEM COMPONENTS:
    - ELECTRONIC KEY READER: P/N - EA-B3X-XXX
    - ELECTRONIC KEY: P/N - EA-B1X-XX-XX
    - POWER WIRE HARNESS: P/N - EA-W22-XXX
  - E. SHIPPED INDIVIDUALLY IN ESD BAG.
  - F. FOR USAGE AND PROGRAMMING INSTRUCTIONS SEE DRAWING J-EA-B90-M.
  - G. MOUNTING HARDWARE NOT PROVIDED. RECOMMEND M4 OR #6 SCREW. DO NOT OVER TIGHTEN.

EA-B20-112	ELECTRONIC KEY CONTROLLER			
SOUTHCO PART NUMBER	TYPE OF COMPONENT	MATERIAL	FINISH	GENERAL NOTES
	THIRD ANGLE PROJECTION			
	MILLIMETERS [IN]			
SURFACE AREA	TOLERANCES UNLESS OTHERWISE NOTED		<b>southco</b> <sup>®</sup> CONNECT · CREATE · INNOVATE ELECTRONIC KEY CONTROLLER	
VOLUME	ALL DIMENSIONS WITHOUT TOLERANCES ARE FOR REFERENCE ONLY.			
PROPRIETARY ITEM	PER ASME Y14.5M-1994	SIZE A3	SYSTEM NX	DWG NO. J-EA-B20-112
EXCEPT FOR USES EXPRESSLY GRANTED IN WRITING, INFORMATION DISCLOSED HEREON IS CONFIDENTIAL AND ALL RIGHTS, PATENT AND OTHERWISE, ARE RESERVED BY SOUTHCO, INC.		DRAWN BY MJS/MJS	DATE 22MAY2009	SCALE 1:1 SHEET 1 OF 1