

REVISION HISTORY			
REV	DATE	BY	DESCRIPTION
B	14JAN2010	MJS/CLB	PRN: P2010-0030

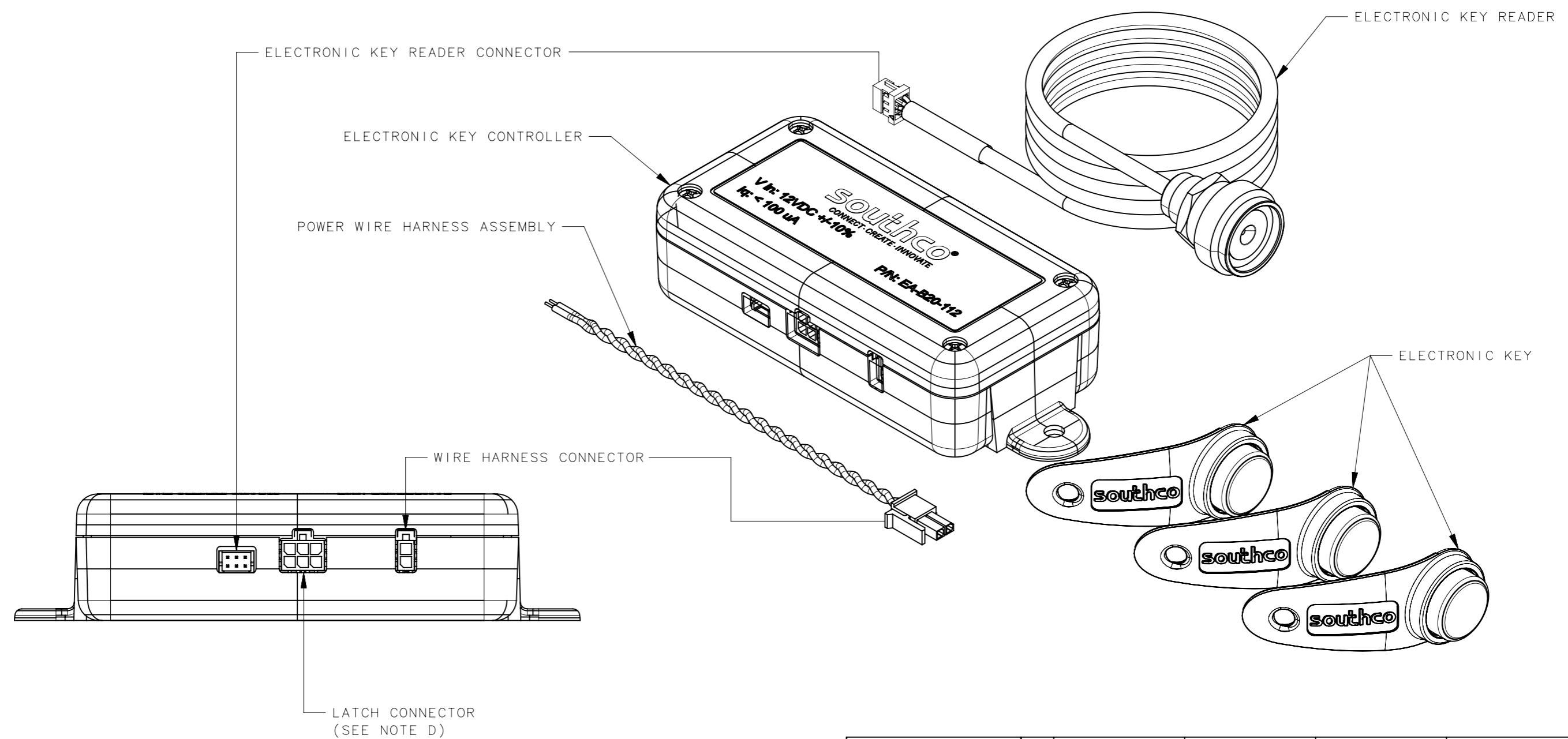

- NOTES:
- A. MATERIAL AND FINISH (ALL COMPONENTS RoHS COMPLIANT)
 1. ELECTRONIC KEY READER - SEE J-EA-B10 FOR DETAILS.
 2. ELECTRONIC KEY CONTROLLER - SEE J-EA-B20-112 FOR DETAILS.
 3. ELECTRONIC KEY ASSEMBLY - SEE J-EA-B30-11 FOR DETAILS.
 4. POWER WIRE HARNESS - SEE J-EA-W22 FOR DETAILS.
 - B. SHIPPED INDIVIDUALLY IN SMALL CARDBOARD BOX.
 - C. CONTROLLER MOUNTING HARDWARE NOT PROVIDED
M4 OR #6 SCREW RECOMMENDED - DO NOT OVER TIGHTEN.
 - D. FOR A COMPREHENSIVE LIST OF COMPATIBLE SOUTHCO LATCHES,
SEE WWW.SOUTHCO.COM
 - E. SEE J-EA-B90-M FOR USER INSTRUCTIONS.

EA-B90-M	1	USER INSTRUCTIONS	-	-	REF. TRADE DRAWING J-EA-B90-M
EA-B20-112	1	ELECTRONIC KEY CONTROLLER	-	-	
EA-B30-117	1	ELECTRONIC KEY READER	SEE NOTE A	SEE NOTE A	
EA-B10-11-01	1	ELECTRONIC KEY	STAINLESS STEEL/ACETAL	RED	SEE J-EA-B10 FOR MORE OPTIONS
EA-B10-11-07	1	ELECTRONIC KEY	STAINLESS STEEL/ACETAL	BLACK	SEE J-EA-B10 FOR MORE OPTIONS
EA-B10-11-09	1	ELECTRONIC KEY	STAINLESS STEEL/ACETAL	GREY	SEE J-EA-B10 FOR MORE OPTIONS
EA-W22-200	1	POWER WIRE HARNESS	-	-	2 METER LENGTH
EA-B90		ELECTRONIC KEY SYSTEM KIT	-	-	
SOUTHCO PART NUMBER	QTY	TYPE OF COMPONENT	MATERIAL	FINISH	GENERAL NOTES

THIRD ANGLE PROJECTION		southco [®] CONNECT • CREATE • INNOVATE		
MILLIMETERS [IN]				
SURFACE AREA XXXXXmm ²		DESCRIPTION Electronic Access Solution ELECTRONIC KEY SYSTEM KIT		
VOLUME XXXXXmm ³				
PROPRIETARY ITEM <small>EXCEPT FOR USES EXPRESSLY GRANTED IN WRITING, INFORMATION DISCLOSED HEREON IS CONFIDENTIAL AND ALL RIGHTS, PATENT AND OTHERWISE, ARE RESERVED BY SOUTHCO, INC.</small>		SIZE A3	SYSTEM NX	DWG NO. J-EA-B90
PER ASME Y14.5M-1994		DRAWN BY MJS/CLB	DATE 18AUG2009	SCALE 1:1
				SHEET 1 OF 1

Electronic Key Controller User Instructions

Specifications

Supply Voltage:	12VDC ± 10%
Quiescent Current:	100µA (max)
Operating Current:	35mA (max)
Command Output Signal Rating:	2A @ 12V (max)
Number of Users:	15 (max)
Access Time:	programmable 5- 30 seconds (default 5 seconds)

CAUTION: The electronic key controller PCA is an ESD-sensitive device. Observe ESD best practices when accessing the PCA to avoid damage to the PCA.

Electronic Key Controller

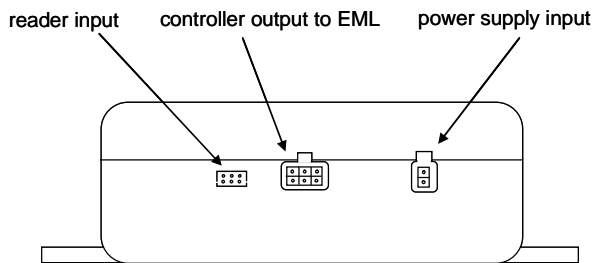

NOTE: This controller is designed to work with Southco electronic key reader part number (EA-B30-xxx).

Assembly and Installation

The electronic key controller is part of a system that requires connection to a power supply, electronic key reader, and electromechanical latch (EML) to function properly.

Power Supply

The controller requires a 12VDC power supply. Be sure to observe correct polarity.

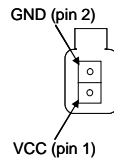

pin #	description
1	VCC (power supply input)
2	GND (ground)

Controller Output to EML

The controller output connector provides a power supply and command output for an electromechanical latch. Please note that these will be the same voltage level as the controller's power supply voltage (12VDC).

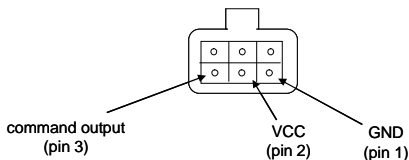

pin #	description
1	GND (ground)
2	VCC (power supply)
3	command output
4	no-connect
5	no-connect
6	no-connect

Electronic Key Reader Input

The electronic key reader reads the ID code from the electronic key and sends it to the controller. The ID code is unique for each electronic key.

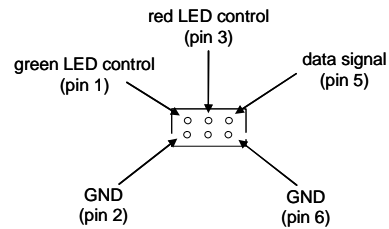

pin #	description
1	green LED control
2	GND (ground)
3	red LED control
4	no-connect
5	data signal
6	GND (ground)

Types of Keys

There are two types of electronic keys for this controller:

1. Programming Key. There is one programming key. This key is used to add and delete users. The programming key cannot be used as a user key.
2. User Key. The controller allows for a maximum of 15 user keys to be enrolled. When an enrolled user key makes proper contact with the reader, the reader will turn green and access will be granted for the programmed access time. Note that to make proper contact, the key must be centered and flat against the reader.

Reader LED Color Codes

Programming Mode

color	description
solid amber	waiting for input
eight green flashes	user key enrolled
eight red flashes	user key deleted
alternating red/green	user key capacity full
one red flash	bad key read

User Mode

color	description
solid green	access granted (enrolled key)
alternating red/green	access denied (un-enrolled key)
three red flashes	bad key read

Electronic Key Controller User Instructions

Enrolling Programming Key (initial setup)

The controller allows for one programming key to be enrolled. By default, the controller is shipped with no programming or user keys enrolled. The first key to be enrolled will become the programming key. To enroll the programming key:

1. Apply power. The reader will flash red/green.
2. Contact the key to the reader. The reader will turn solid amber if enrollment is successful.

Once the programming key has been enrolled, the controller will enter its programming mode, indicated by the reader turning amber.

Enrolling User Keys

1. Contact the programming key to the reader (skip this step if this is during initial setup).
 - a. The reader will turn solid amber to indicate programming mode has been entered.
 - b. If the key made poor contact with the reader, the reader will flash red three times to indicate a bad read.
2. Contact the user key to the reader.
 - a. The reader will flash green eight times if enrollment is successful.
 - b. If the key made poor contact with the reader, the reader will flash red once to indicate a bad read.
3. To enroll additional user keys, wait for the reader to turn solid amber, and then repeat Step #2.

Note: The controller supports a maximum of 15 user keys. The reader will flash red/green if more than 15 keys are attempted to be enrolled.
4. Contact the programming key to the reader when done. The reader will turn "off" indicating that enrollment is complete. The controller will exit programming mode.

Deleting User Keys

1. Contact the programming key to the reader.
 - a. The reader will turn solid amber to indicate programming mode has been entered.
 - b. If the key made poor contact with the reader, the reader will flash red three times to indicate a bad read.
2. Contact the user key to the reader.
 - a. The reader will flash red eight times to indicate that removal was successful.
 - b. If the key made poor contact with the reader, the reader will flash red once to indicate a bad read.
3. To delete additional user keys, wait for the reader to turn solid amber, and then repeat Step #2.
4. Contact the programming key to the reader when done. The reader will turn "off" indicating that removal is complete. The controller will exit programming mode.

Changing Access Time

The default access time is 5 seconds. The access time can be increased in 5 second increments to a maximum of 30 seconds by pressing the S1 switch on the PCA inside the controller box while the controller is in programming mode.

1. Contact the programming key to the reader.
 - a. The reader will turn solid amber to indicate programming mode has been entered.
 - b. If the key made poor contact with the reader, the reader will flash red three times to indicate a bad read.

2. Press the S1 switch on the PCB inside the controller box to add 5 seconds to the access time. The reader will blink once.
3. Repeat Step #2 to increase access time in 5 second increments.

Note: The maximum access time is 30 seconds. The reader will alternate flashing red/green and the access time will be set to 5 seconds if the 30 second maximum is exceeded.
4. Contact the programming key to the reader when done. The reader will turn "off" indicating that the access time has been set. The controller will exit programming mode.

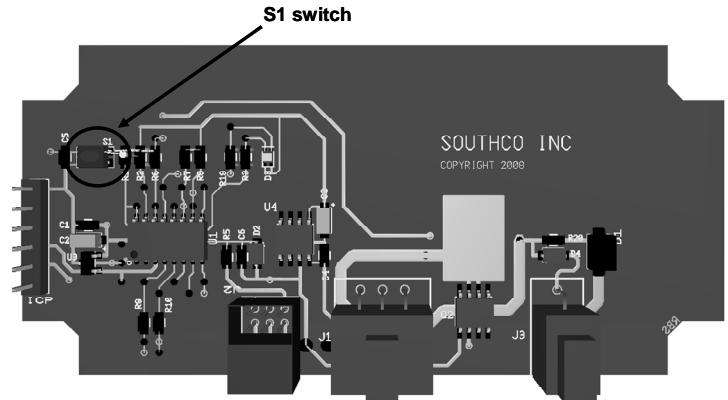

Resetting the Controller

Resetting the controller will erase the programming and all user key permissions. Access time will be reset to 5 seconds. To reset the controller:

1. Remove power.
2. Press and hold the S1 switch on the PCB inside the controller box while re-applying power. The reader will be amber at power-on while the S1 switch is pressed in.
3. Release the S1 switch. The reader will alternate red/green.

Follow the instructions from "**Enrolling Programming Key (initial setup)**" section to enroll the programming key.

Normal Use

For normal use, contact a user key to the reader.

If an enrolled user key makes proper contact with the reader, the reader will turn solid green and access will be granted for the programmed access time.

If an un-enrolled key makes contact with the reader, the reader will alternate flashing red/green for approximately 3 seconds.

If a key does not make proper contact with the reader, the reader will flash red three times to indicate a bad read.

CAUTION: A controller that has been programmed is non-returnable. Please use caution in programming functions so as not to render the controller unusable.

For technical support of this product contact: info@southco.com or visit: www.southco.com.