

NOTES:

- A. ELECTRICAL SPECIFICATIONS:
- SUPPLY VOLTAGE: 12V±10%
  - IDLE CURRENT: 90 MILLIAMPS MAX. (NO ATTACHED DEVICES)
  - OPERATING CURRENT: 110 MILLIAMPS MAX. (NO ATTACHED DEVICES)
  - OPERATING TEMPERATURE: 0° TO 50° CELSIUS
  - FREQUENCY OF OPERATION 125kHz ASK (EM)
  - MAXIMUM READ RANGE: 10 CENTIMETERS, DEPENDING ON INSTALLATION
  - COMPATIBLE WITH EA-C1-01X PROXIMITY CARD
- B. MATERIALS
- FRONT COVER - PC PLASTIC
  - CONTROLLER HOUSING - PC PLASTIC
  - BUTTONS - ABS PLASTIC
  - BUTTON FRAME - ABS PLASTIC
  - GASKET - SILICONE RUBBER
- C. CONNECTIONS:
- JA = DOOR ACCESS CONNECTOR
  - JB = LOCKOUT ALARM CONNECTOR
  - JC = TAMPER SWITCH OUT PUT CONNECTOR
  - JD = EXTERNAL WIEGAND READER CONNECTOR
  - REFER TO USER INSTRUCTIONS (J-EA-P1-01-M) FOR MORE DETAIL
- △ CAUTION: PRODUCT CAN BE DAMGED IF WIRED INCORRECTLY. FOLLOW WIRING INSTRUCTIONS IN J-EA-P1-01-M.
- D. USE A 1.5cm (MIN) NON-METAL SPACER IF MOUNTING THE CONTROLLER TO A METAL SURFACE MOUNTING DIRECTLY TO METAL MAY SIGNIFICANTLY DECREASE READ RANGE. CONTACT SOUTHCO FOR DETAILS.
- E. IF INSTALLING MULTIPLE CONTROLLER UNITS, LOCATE UNITS 30 CENTIMETERS (MIN) APART.
- F. 2 MOUNTING SCREWS PROVIDED  
MOUNT WITH M3.5 SCREWS. HEAD DIAMETER NOT TO EXCEED 6.0 MILLIMETER.  
MAXIMUM TORQUE FORCE = 1.1 N m  
MINIMUM TORQUE FORCE = 0.7 N m
- G. ONE SUPPRESSOR DIODE PROVIDED.  
CAN BE USED WHEN CONNECTING AN EXTERNAL RELAY (NOT PROVIDED) OR MULTIPLE CONTROLLERS TO A SINGLE LATCH.
- H. SEE ORDERING INFORMATION FOR COLOR AND LOGO OPTIONS.
- I. FOR INDOOR USE ONLY

**southco**

PROPRIETARY ITEM - EXCEPT FOR USES EXPRESSLY GRANTED IN WRITING INFORMATION DISCLOSED HEREON IS CONFIDENTIAL AND ALL RIGHTS PATENT AND OTHERWISE ARE RESERVED BY SOUTHCO, INC.

EA RF PROXIMITY CONTROLLER ASSEMBLY

DATE	DRAWN	CHKD	SCALE
09DEC2008	ACH	MJS	NTS

DRAWING NUMBER  
J-EA-P1-01

REV	DATE	DRAWN/CHKD	DESCRIPTION	ITEM	PART NUMBER
A	09DEC2008	ACH/MJS	INITIAL DRAWING RELEASE	ASSEMBLY	SEE LEGEND
B	11AUG2009	ACH/MJS	PRN: P2009-0950	USER INSTRUCTIONS	EA-P1-01-M
C	24AUG2009	ACH/MJS	PRN: P2009-1001		

**MILLIMETERS**  
TOLERANCES UNLESS OTHERWISE NOTED  
ALL DIMENSIONS WITHOUT TOLERANCES ARE FOR REFERENCE ONLY.

THIRD ANGLE PROJECTION

A3 PAPER SIZE

1 OF 2

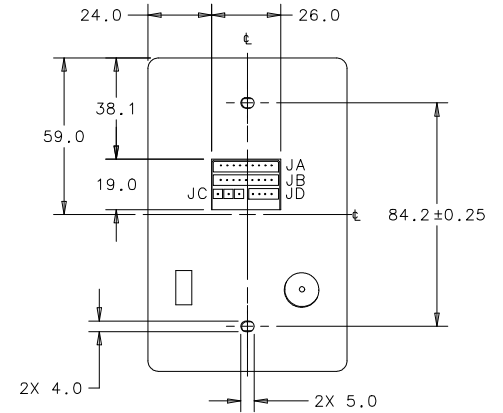
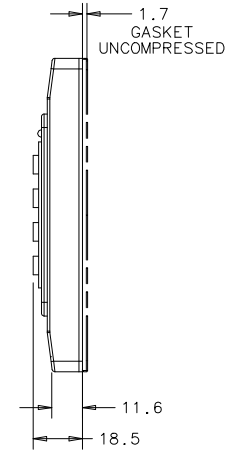
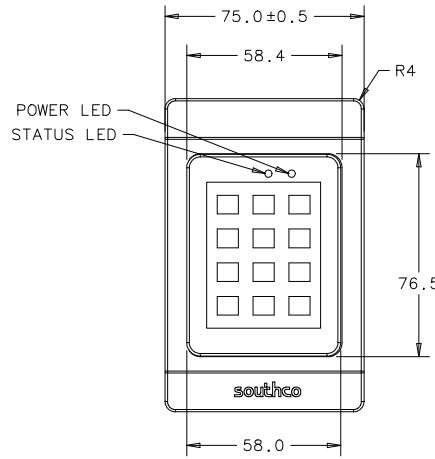

P/N EA-P1-01X-9 SHOWN

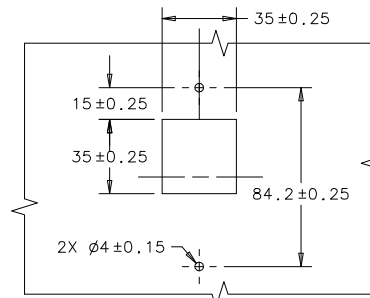
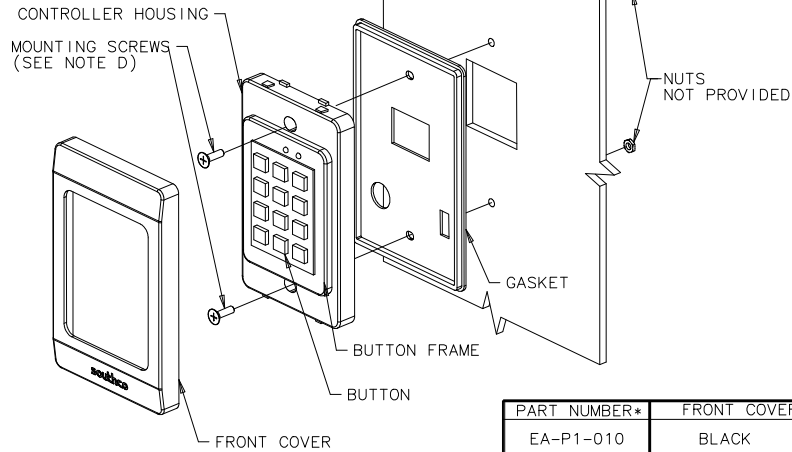

SURFACE MOUNT PREP (FRONT VIEW)

ORDERING INFORMATION

PART NUMBER*	FRONT COVER	CONTROLLER HOUSING	BUTTON	BUTTON FRAME
EA-P1-010	BLACK	BLACK	BLACK WITH WHITE MARKINGS	BLACK
EA-P1-011	WHITE	WHITE	WHITE WITH BLACK MARKINGS	BLACK
EA-P1-012	COOL GRAY 2 C	COOL GRAY 2 C	WHITE WITH BLACK MARKINGS	BLACK

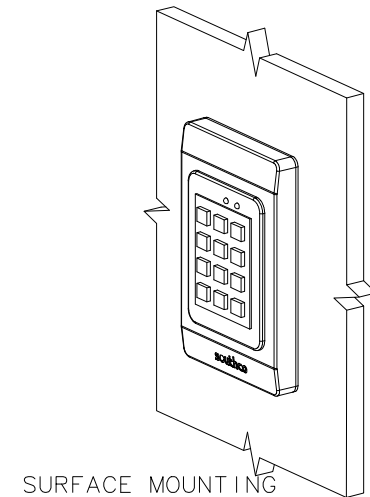

\* ADD -9 TO PART NUMBER FOR SOUTHCO LOGO (FOR EXAMPLE, EA-P1-010-9)

**southco**

PROPRIETARY ITEM - EXCEPT FOR USES EXPRESSLY GRANTED IN WRITING INFORMATION DISCLOSED HEREON IS CONFIDENTIAL AND ALL RIGHTS PATENT AND OTHERWISE ARE RESERVED BY SOUTHCO, INC.

EA RF PROXIMITY CONTROLLER ASSEMBLY

DATE	DRAWN	CHKD	SCALE
09DEC2008	ACH	MJS	NTS

DRAWING NUMBER  
J-EA-P1-01

REV	DATE	DRAWN/CHKD	DESCRIPTION	ITEM	PART NUMBER
A	09DEC2008	ACH/MJS	INITIAL DRAWING RELEASE	ASSEMBLY	SEE LEGEND
B	11AUG2009	ACH/MJS	PRN: P2009-0950	USER INSTRUCTIONS	EA-P1-01-M
C	24AUG2009	ACH/MJS	PRN: P2009-1001		

**MILLIMETERS**  
TOLERANCES UNLESS OTHERWISE NOTED  
ALL DIMENSIONS WITHOUT TOLERANCES ARE FOR REFERENCE ONLY.

THIRD ANGLE PROJECTION

A3 PAPER SIZE

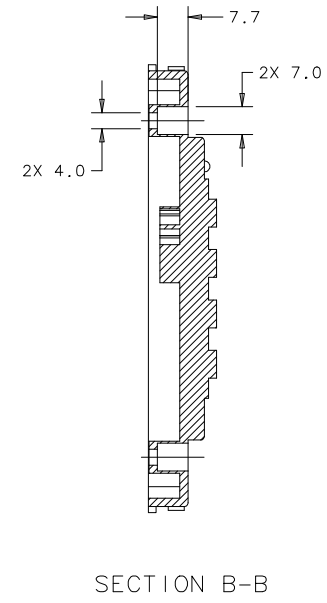
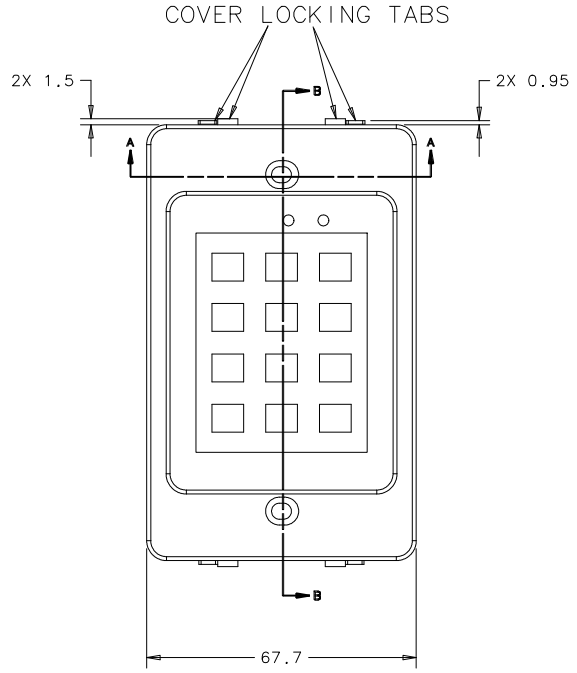
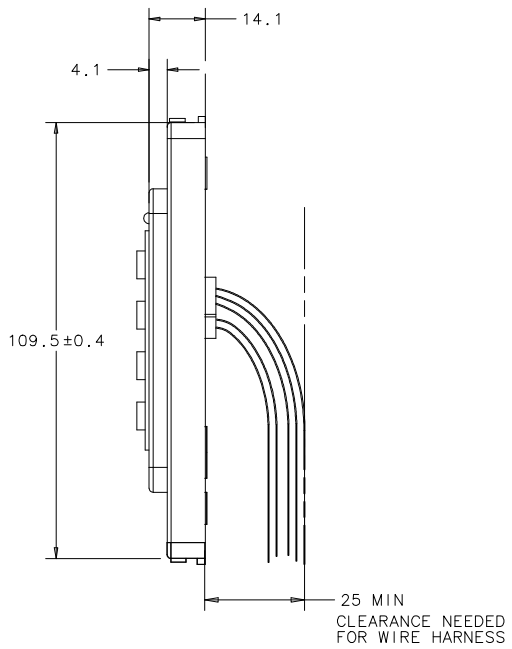
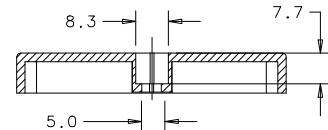

# EA-P1 Proximity Controller Operating Instructions

## Package Contents

- Stand alone PIN + Prox Controller
- Operating instructions
- Wire harness for JA door access connector (9-wires with blue connector)
- Wire harness for JB lockout alarm connector (8-wires with white connector)
- Wire harness for JC tamper switch connector (3-wires with blue connector)
- Wire harness for JD external Wiegand reader connector (4-wires with white connector)
- Diode (IN4007GW)
- 2 mounting screws

## EA-P1-01x Standalone Proximity Controller

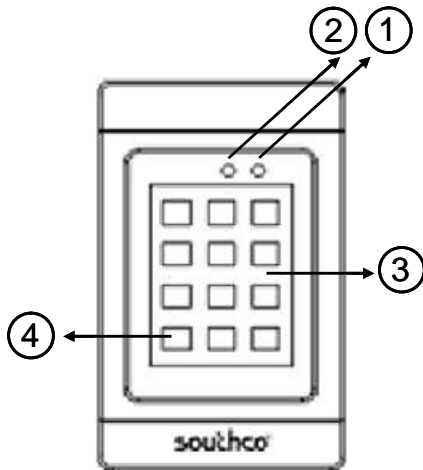

1. Power ON LED
2. Bicolor (red/green) Status LED
3. PIN + Prox Controller
4. Return to Ready State

## Features

- Supports up to 9,999 user cards and five PIN codes
- Multiple modes of operation: card-only, card or PIN, card and PIN, bypass mode
- Programmable door release time (1 to 98 seconds)
- Programmable failed attempts (1 to 99)
- Programmable lockout time (1 to 98 seconds)
- Programmable user and supervisor code length (4 to 8 digits)
- LED indicators: Power and Status
- Supports connection to an external 26-bit Wiegand reader
- Non-volatile memory will retain data when power is removed
- Tamper switch
- For indoor use only

## Controller Mounting and Installation

Please refer to Southco trade drawing J-EA-P1-01 for mounting and installation details.

## Specifications

User Cards Supported:	9,999
Supervisor Cards Supported:	9
PIN Codes Supported:	5
Power:	12VDC ± 10%
	90mA maximum (standby mode), no attached devices
	110mA maximum (operating mode), no attached devices
Transmit Frequency:	125kHz ASK (EM)
Card Reading Range:	up to 10 cm (depending on installation)
Default Access Time:	4 seconds
Operating Temperature:	0-50 °C
Operating Humidity:	20-90% RH, No condensation
Dimensions:	118 mm x 75 mm x 19 mm

## Default Settings

The table below describes the default settings of the EA-P1-01x controller.

Description	Default Value
Access Time	4 seconds
PIN Code Length	4 digits
Number of Failed Attempts	3
Lockout Alarm Time	60 seconds
Mode of Operation	card only

## Enrolling Supervisor Card

To enroll the supervisor card:

1. Apply power to the unit.
2. Switch the two DIP switches on the rear of the unit to "ON".
3. Hold the supervisor card to the unit. The status LED will flash red/green if the card has been successfully enrolled.
4. Switch the two DIP switches on the rear of the unit to their original positions ("1" and "2").

To enroll additional supervisor cards, repeat Steps 1-3 above. Note that the last digit in the bottom right corner of the prox card must be different for each supervisor card (see below).

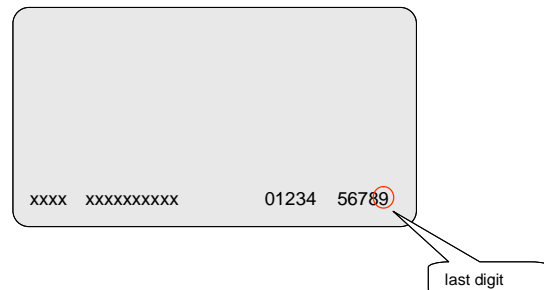

**NOTE:** Once a supervisor card has been enrolled, it cannot be deleted.

## Enrolling User Cards

User cards can be enrolled individually or in blocks. To enroll an individual user card:

1. Hold the supervisor card to the unit.
2. Enter 6-6-6-6 on the keypad.
3. Enter the last four digits on the bottom right corner of the prox card to be enrolled (example below).

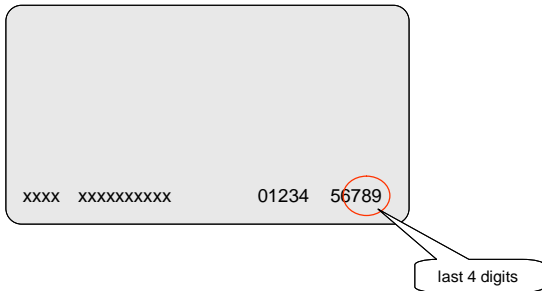

4. To enroll another card, repeat Step #3 while the status LED is still green.
5. The unit will return to user mode when the status LED turns off or if the "\*" (return-to-ready state) key is pressed.

To enroll a block of cards:

1. Hold the supervisor card to the unit.
2. Enter 6-6-0-0 on the keypad.
3. Enter the last four digits of the lowest card in the block to be enrolled.
4. Enter the last four digits of the highest card in the block to be enrolled.
5. The unit will return to user mode when the status LED turns off or if the "\*" (return-to-ready state) key is pressed.

For example, entering 6-6-0-0 8-3-0-0 8-3-0-5 will enroll cards whose last four digits range from 8300 to 8305.

## Deleting User Cards

User cards can be deleted individually or in blocks. To delete an individual user card:

1. Hold the supervisor card to the unit.
2. Enter 7-7-7-7 on the keypad.
3. Enter the last four digits on the bottom right corner of the prox card to be deleted.
4. To delete another card, repeat Step #3 while the status LED is still green.
5. The unit will return to user mode when the status LED turns off or if the "\*" (return-to-ready state) key is pressed.

To delete a block of cards:

1. Hold the supervisor card to the unit.
2. Enter 7-7-0-0 on the keypad.
3. Enter the last four digits of the lowest numbered card in the block to be deleted.
4. Enter the last four digits of the highest numbered card in the block to be deleted.
5. The unit will return to user mode when the status LED turns off or if the "\*" (return-to-ready state) key is pressed.

For example, entering 7-7-0-0 8-3-0-0 8-3-0-5 will delete cards whose last four digits range from 8300 to 8305.

## Enrolling and Changing PIN Numbers

Five PIN numbers can be enrolled. The default PIN number length is four digits. To enroll a PIN number:

1. Hold the supervisor card to the unit.
2. Enter 4-6-0-*n* on the keypad, where *n* is the slot number (range 1-5).
3. Enter the desired four digit PIN number.

## Deleting PIN Numbers

PIN numbers may be deleted either individually or all at once. To delete an individual PIN number:

1. Hold the supervisor card to the unit.
2. Enter 4-7-0-*n* on the keypad, where *n* is the slot number (range 1-5).

To delete all PIN numbers:

1. Hold the supervisor card to the unit.
2. Enter 4-7-0-0 on the keypad.

## Changing PIN Number Length

The default PIN number length is four digits. It can be programmed to be four to eight digits. To change the PIN number length:

1. Hold the supervisor card to the unit.
2. Enter 4-8-0-*d*, where *d* is the number of digits in the PIN number (range 1-8).

**⚠ NOTE:** Changing the PIN code length will not delete programmed PIN numbers. Changing the PIN code length to be longer than PIN numbers stored in memory will result in the PINs being unusable. For example, if a four digit PIN is stored in memory, and the PIN number length is then changed to eight, then the PIN cannot be used.

However, if the PIN length is changed to be shorter than programmed

# EA-P1 Proximity Controller

## Operating Instructions

PIN numbers already enrolled, then only the first **d** digits need to be entered to be granted access, where **d** is the newly programmed PIN code length. For example, if a four digit PIN has been programmed and the PIN code length is later changed to three digits, only the first three digits of the PIN need to be entered.

### Setting the Mode of Operation

The unit can be set to one of four operating modes:

- **Card-Only:** Access granted when a valid card is held to the unit. This is the default mode.
- **Card and PIN:** Access granted when a valid card is held to the unit and then an enrolled PIN is entered.
- **Card or PIN:** Access granted when either a valid card is held to the unit or an enrolled PIN is entered.
- **Bypass:** Access granted until bypass mode exit command is issued.

To set the unit to operate in these modes:

#### *Card-Only*

1. Hold the supervisor card to the unit.
2. Enter 3-2-0-0 on the keypad.

#### *Card and PIN*

1. Hold the supervisor card to the unit.
2. Enter 3-3-0-0 on the keypad.

#### *Card or PIN*

1. Hold the supervisor card to the unit.
2. Enter 3-4-0-0 on the keypad.

#### *Bypass Mode*

1. Hold the supervisor card to the unit.
2. Enter 3-8-0-1 on the keypad to enter bypass mode (Enter 3-8-0-0 to exit bypass mode)

**NOTE:** In all modes, access will be granted if the supervisor card is held to the unit and 3-6-0-1 is entered on the keypad.

### Changing Door Access Time

The default door access time is four seconds. To change the access time:

1. Hold the supervisor card to the unit.
2. Enter 2-1-**tt** on the keypad, where **tt** is the desired door access time in seconds (range 01-98).

**NOTE:** If 2199 is entered, the unit will allow access until a valid card/PIN is entered.

### Changing Lockout Alarm Time

The default door access time is sixty seconds. To change the access time:

1. Hold the supervisor card to the unit.
2. Enter 2-2-**tt** on the keypad, where **tt** is the desired lockout alarm time in seconds (range 01-98).

**NOTE:** If 2299 is entered, the unit will continue to assert the lockout alarm until a valid card/PIN is entered.

### Changing Number of Failed Attempts

The default number of failed attempts is three. To change the number of failed attempts:

1. Hold the supervisor card to the unit.
2. Enter 2-4-**nn** on the keypad, where **nn** is the desired number of failed attempts (range 01-99)

Unless a valid user card is presented to the controller, the controller will assert the lockout alarm on the next failed attempt.

### Resetting the Unit

Resetting the unit will restore the factory settings. It will not delete PIN numbers or enrolled user and supervisor cards. To reset the unit:

1. Hold the supervisor card to the unit.
2. Enter 0-8-0-0 on the keypad.

### Auxiliary Input

The EA-P1-01x controller has an auxiliary input that can be connected to a momentary push-button. Pin 6 from the JA connector (green wire) is the auxiliary input. When the auxiliary input is 12VDC, the controller will grant access while the input is asserted plus the programmed access time. Connect a momentary push-button switch between the input lead and a 12VDC source to use this feature. **NOTE:** The unit will beep while the input is asserted.

### Lockout Alarm (JB Connector)

The EA-P1-01x controller provides a relay output that is activated when the keypad is locked out due to reaching the number of allowed failed attempts. This will cause the relay to close (i.e. drive the voltage at the COM terminal) for the programmed keypad lockout time.

# EA-P1 Proximity Controller Operating Instructions

## Tamper Switch (JC Connector)

The JC connector can be used to monitor the status of the tamper switch. When the tamper switch is closed, the NO signal will be driven to the same voltage level as the COM signal. When the tamper switch is open, the NC signal will be driven to the same voltage level as the COM signal. See Wiring Diagram for pinout.

## Connecting to Wiegand Reader (JD Connector)

The JD connector can be used to connect a 26-bit Wiegand reader to the EA-P1-01x. Supervisor and user cards do not need to be re-enrolled to work with the Wiegand reader. **NOTE:** Only readers that provide a 26-bit Wiegand output are supported. See Wiring Diagram for pinout.

## Wiring Multiple Controllers

A diode is provided with the EA-P1-01x controller. The diode allows for a keypad to be isolated when multiple controllers are connected to the same latch. Refer to the figure below for wiring details when using the diode when using multiple controllers. Observe proper polarity when connecting the diode.

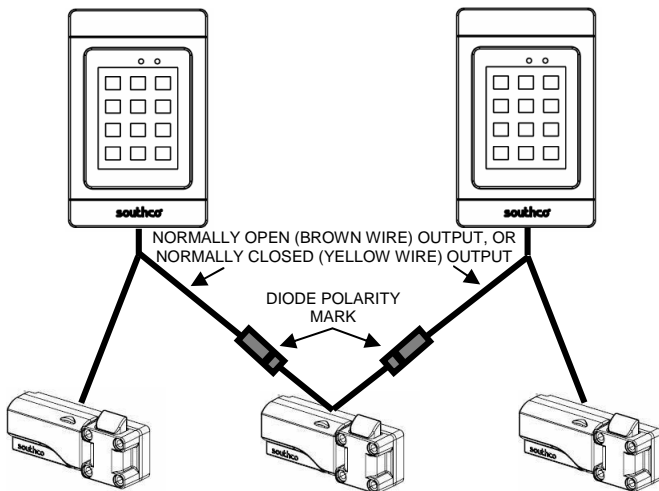

## Connecting to an Inductive Load

A diode is provided with the EA-P1-01x controller. This diode should be used when connecting to a device with an inductive load (for example, a relay or door strike) to protect the controller from a reverse voltage spike. The diode should be placed in parallel with the coil, as shown in the figure below. Observe proper polarity when connecting the diode.

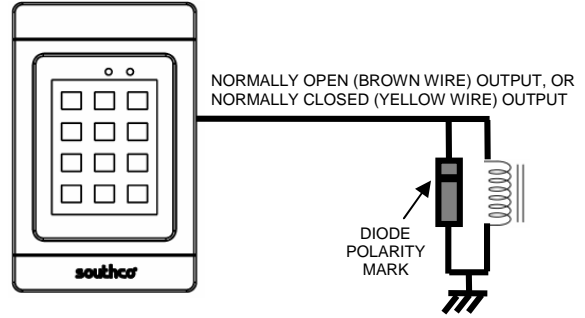

## Wiring Diagram

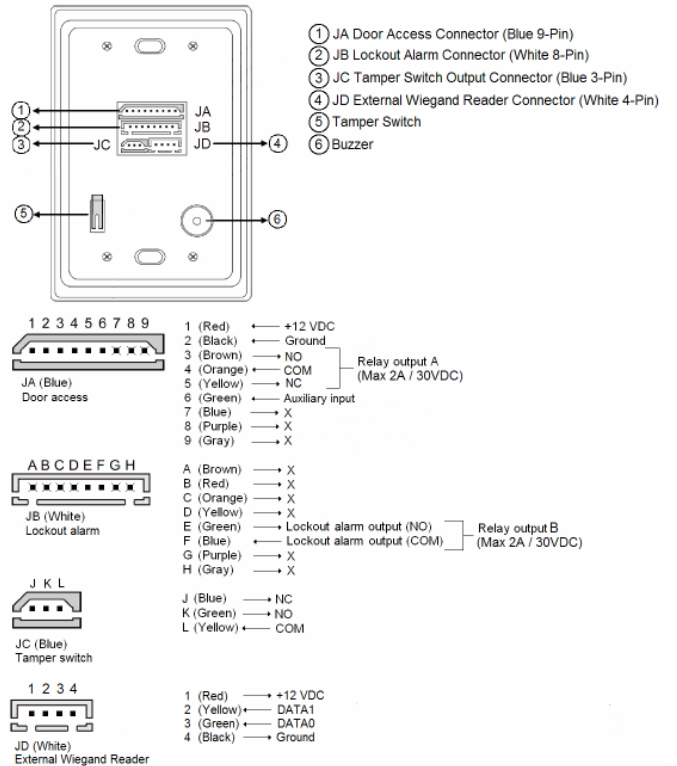

**CAUTION:** Product can be damaged if wired incorrectly. Follow wiring diagram above.

**CAUTION:** A controller that has been programmed is non-returnable. Please use caution in programming functions so as not to render the keypad unusable.

For technical support of this product contact: [info@southco.com](mailto:info@southco.com) or visit: [www.southco.com](http://www.southco.com)