

REV	DATE	DRAWN/CHKD	DESCRIPTION	COMPONENT	MATERIAL	FINISH	DATE	DRAWN/CHKD	SCALE	DRAWING NUMBER
1	13 JUN 2002	VNI/DLH	PRN: P2002-0405	HOUSING	PC/ABS	SEE TABLE	13 JUN 2002	VNI	1:1	J-M1-2A-15
A	19 JUL 2002	VNI/CHW	PRN: P2002-0489	KNOB	SEE TABLE	SEE TABLE				
			RELEASED FOR PRODUCTION	INTERNAL CYLINDER	ACETAL	SEE TABLE				
B	08 JAN 2003	VNI/AJH	PRN: P2002-0934	PAWL	GR NYLON	BLACK				
				KNOB SPRING	300 SERIES STAINLESS STEEL	PASSIVATED				
				PAWL SPRING	300 SERIES STAINLESS STEEL	PASSIVATED				
				PAWL NUT	GR NYLON	BLACK				
				KEEPER	GR NYLON	BLACK				

MILLIMETERS

ALL DIMENSIONS WITHOUT TOLERANCES ARE FOR REFERENCE ONLY.

A3
PAPER
PROJECTION
STYLE

NOTES:

- A. INSTALLATION INSTRUCTIONS:
 1. PREPARE DOOR AND FRAME AS SHOWN. THE FOLLOWING OPTIONAL PANEL PREPARATIONS MAY BE USED TO ENSURE LATCH ANTI-ROTATION:
 6. ALIGNMENT STEM HOLE FOR PANELS THICKER THAN 6.4
 6. ALIGNMENT STEM HOLE FOR PANELS THICKER THAN 6.4
 - NOTE: ALIGNMENT STEM FOLDS AWAY IF ROUND HOLE PREPARATION IS USED.
 2. INSERT LATCH THROUGH HOLE AND TIGHTEN NUT (TIGHTENING TORQUE IS 4.2 N m).
 3. FOR ALIGNMENT STEM USAGE, PUSH ALIGNMENT STEM INTO SEMI-CIRCULAR HOLE AND HOLD IN PLACE UNTIL NUT IS TIGHTENED.
 4. INSTALL KEEPER.

- B. CAUTION - AVOID PROLONGED CONTACT WITH SOLVENTS. FOR CLEANING, WIPE WITH MILD HOUSEHOLD CLEANER OR DETERGENT.

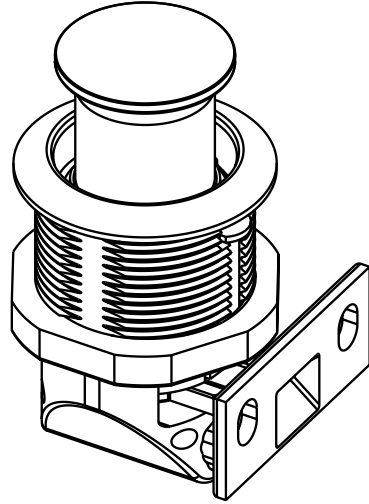

MATERIAL AND FINISH INFORMATION

ASSEMBLY PART NUMBER FINISH/COLOR
 M1-2A-15-1 CHROME KNOB AND HOUSING
 M1-2A-15-5 BLACK KNOB AND HOUSING
 M1-2A-15-8 GOLD KNOB AND HOUSING
 M1-2A-15-14 RED KNOB AND HOUSING

INTERNAL CYLINDER IS WHITE FOR PART NUMBERS M1-2A-15-1 AND M1-2A-15-8
 INTERNAL CYLINDER IS BLACK FOR PART NUMBERS M1-2A-15-5 AND M1-2A-15-14

KNOB MATERIAL
 ABS
 PC/ABS
 ABS
 PC/ABS

